

INSTALLATION DIAGRAM

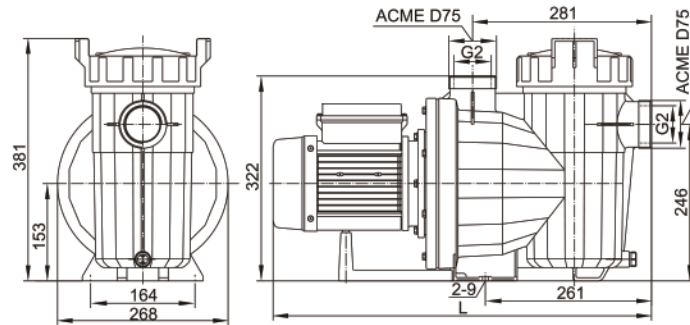
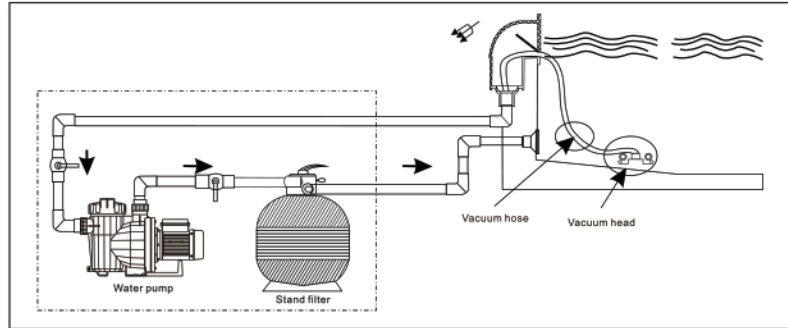

Model	Qmax (l/min)	Hmax (m)	Power(P ₁)		L Single-phase
			KW	HP	
PA - 075	280	12	0.55	0.75	576
PA - 100	310	15.5	0.75	1.0	576
PA - 150	400	18	1.1	1.5	576
PA - 200	470	19	1.5	2.0	595
PA - 250	520	19.5	1.85	2.5	595
PA - 300	550	22	2.2	3.0	595
PA - 400	600	24	3.0	4.0	636

⚠ This appliance is not intended for use by persons (including children) with reduced physical, sensory or mental capabilities, or lack of experience and knowledge, unless they have been given supervision or instruction concerning use of the appliance by a person responsible for their safety.

Type Y attachment - Damaged supply cords to be replaced by the Manufacturer, service agent or similarly qualified person to avoid hazard.

V/ Hz esp: See pump nameplate. Liquid temperature: 40°C ~ 50°C
Storage temperature: -10°C ~ +50°C. Relative Air Humidity: 95% Max.

Edition: 2022-03

PARIS PUMP

SELF-PRIMING PUMP
SUPER SILENT



IMPORTANT SAFETY INSTRUCTIONS

When installing and using this electrical equipment, basic safety precautions should always be followed, including the following:

1. READ AND FOLLOW ALL INSTRUCTIONS

2. WARNING Risk of Electrical Shock.

Connected only to grounding type receptacle protected by a ground fault circuit interrupter (GFCI). Contact a qualified electrician if you cannot verify that the receptacle is protected by GFCI.

3. CAUTION Means for disconnection must be incorporated in the fixed wiring in accordance with the wiring rules.

4. CAUTION In case the running parts will injure people, don't make the electric pump connected power before then pipeline have been connected.

5. WARNING If the supply cord is damaged, it must be replaced by the manufacturer, its service agent or similarly qualified persons in order to avoid a hazard.

6. The appliance can be used by children aged from 8 years and above and persons with reduced physical, sensory or mental capabilities or lack of experience and knowledge if they have been given supervision or

instruction concerning use of the appliance in a safe way and understand the hazards involved. Children shall not play with the appliance.

Cleaning and user maintenance shall not be made by children unless they are older than 8 and supervised. Children should be supervised to ensure that they do not play with the appliance.

Children must be supervised so that they do not play with the device.

7. CAUTION In order to avoid a hazard due to inadvertent resetting of the thermal cut-out, this appliance must not be supplied through an external switching device, such as a timer, or connected to a circuit that is regularly switched on and off the utility

8. WARNING Disconnect the pump from the supply mains before carrying out user maintenance such as cleaning the filter.

9. THIS APPLIANCE IS ONLY FOR

HOUSEHOLD AND INDOOR USE ONLY.

10. THIS APPLIANCE IS INTENDED FOR SWIMMING POOL ONLY.

11. SAVE THESE INSTRUCTIONS.



Correct Disposal of this product:

This marking indicates that this product should not be disposed with other household wastes throughout the EU. To prevent possible harm to the environment

or human health from uncontrolled waste disposal, recycle it responsibly to promote the sustainable reuse of material resources. Do not return your used device, please use the return and collection systems or contact the retailer where the product was purchased. They can take this product for environmental safe recycling.

1. General

These instructions are for correct installation, and optimum performance of the pumps, so they should be read carefully. These are single-stage centrifugal pumps designed to operate with compact swimming pumps. They are equipped with a total-emptying system to prevent the discharge of residual liquid in each stopping.

These units are designed to operate with clean water at a maximum water temperature of 50°C. Built of top quality materials, they are subjected to strict hydraulic and electrical controls and are carefully verified. Correct installation is ensured by following these instructions and those of the wiring diagram; otherwise, overloads may be produced in the motor. We decline responsibility for any damage caused by not following these instructions.

2. INSTALLATION



Through the holes in the supports to prevent undesirable noise and vibration. The suction, pipe of the pump should be as short as possible. The rating Label must be visible after installation.

Parts containing live parts, except parts supplied with safety extra low voltage <12V, must be inaccessible to a person in the swimming pool. For Class I devices that do not have a plug, they must be permanently connected to a fixed wiring. Part including electrical components except remote control devices must be located or fixed.

3. PIPE ASSEMBLY

The suction and discharge pipes should have a diameter equal to or greater than that of the intake tapping of the pump. Avoid traps as, in addition to affecting efficiency, they impede total overall emptying. The suction and discharge pipes should not rest on the pump in any case. Seal all the connectors and unions well. Avoid any dripping on the motor, which would unfailingly damage it. The suction and discharge pipes should not rest above the pump in any case. Seal all the connectors and unions well. Avoid any dripping on the motor, which would unfailingly damage it.

4. ELECTRICAL CONNECTION



The electrical installation should have a multiple separation system with contacts opening at least 3mm.

For continued protection against possible electric shock this unit is to be mounted to the base in accordance with the installation instructions.

- 1). The pump is to be supplied by an isolating transformer or supplied through a residual current device (RCD) having a rated residual operating current not exceeding 30mA. The supply cable should comply with EMC standards.
- 2). Single-phase motors have built-in thermal protection. The electric connection must be carried out by qualified staff following strictly the "EN60335-2-41" standard. Be sure that the earth cable connection is correctly made. Be sure that the equipotential connection between the swimming pool and the pump is correctly. Wires serving as equipotential bonding conductors shall have a cross sectional area between 2.5 mm² and 6 mm² and shall be equipped with the terminal suitable receptacle.

5. CONTROLS PRIOR TO INITIAL START-UP



Verify that the pump shaft turns freely. Check that the mains voltage and frequency are according to the name plate.

The pump should be equipped with a system to prevent the pump from starting up if a minimum water level is not present. Check the rotating direction of the motor, which should concur with that indicated on the fan cover. If the motor does not start up, try to locate the problem in the table of most common faults and their possible solutions that is provided further on.

THE PUMP SHOULD NEVER OPERATE DRY.

6. Start-up

Start electrically the pump only when the suction and discharge pipes are connected to the corresponding inlets and outlets. Check that there is no obstacle in the pipes. Apply voltage to the motor and suitably adjust the jets to obtain the desired flow.

7. Maintenance and clean

Our pumps do not require any special maintenance or programming. If the pump will be idle for a long period of time, it is recommended to disassemble, clean and store it in a dry, well-ventilated place. Pump can be automatically empty water after correct installation. When the pump needs to clean (1) Filled with water to the level position of the nozzle, (2) operating 2-3 minutes, (3) exhausting water off after engine stop.

8. Trouble Shooting Guide

SYMPTOM	POSSIBLE CAUSE	CHECK
PUMP DOES NOT TURN	NO POWER TO PUMP	-incoming power to the pump? -Is circuit breaker on? -Is GFCI operating properly?
PUMP NOT PUMPING PROPERLY	BLOCKAGE OR LEAK	-Jets should be pointed away from the suction inlet so air is not forced into pump suction -Is the in-tub suction inlet blocked or covered? -Is there any debris in the pump housing? -Is there a leak in the piping or the pump?
	LOW VOLTAGE	-Is the proper voltage applied to the pump? -Is there an extension cord being used?

