

★ MULTI-PORT VALVE

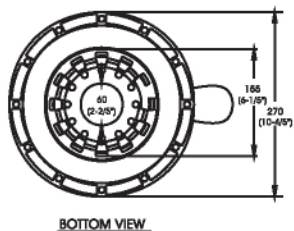

BOTTOM VIEW

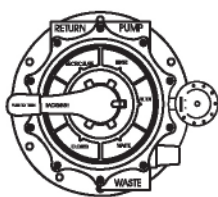

TOP VIEW

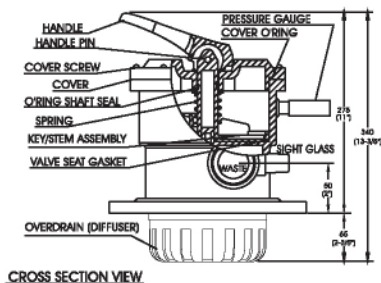

CROSS SECTION VIEW

FILTER

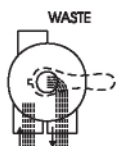

PUMP RETURN

BACKWASH



PUMP RETURN

RINSE



PUMP RETURN

WASTE

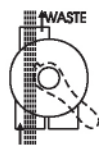

PUMP RETURN

RECIRCULATE



PUMP RETURN

CLOSED



PUMP RETURN

FUNCTIONS OF VALVE POSITIONS

★ VALVE POSITION	Function
★ FILTER	Normal Filtration and Vacuuming
★ BACKWASH	Cleaning Filter by reversing the flow
★ RINSE	Used after backwash to flush dirt from valve
★ WASTE	By-passes filter, used for vacuuming to waste or lowering water level
★ RECIRCULATE	By-passes filter for circulating water to pool
★ CLOSED	Shuts off all flow to filter or pool

★ GENERAL

- A connector is provided for an optional installation of pressure gauge.
- Piping stops are provided to prevent over-tightening. Always use Teflon pipe tape for connections to provide a good, "living" seal. Add extra sealant if male pipe fitting is undersized.
- SERVICING VALVE. If it becomes necessary to service or gain access to the key or valve gasket:
 - Set handle in filter position.
 - Remove cover screws.
 - Lift cover and key assembly out.

★ TO ASSEMBLE

- Place valve key so that wedge opening is at TOP (handle in Filter position). Flat edge of cover screw lug should align with flat edge of body screw lug.
- Position cover O'Ring.
- Secure assembly to body with cover screws. Tighten cover screws evenly and alternately. Do not over-tighten.

APT Series Berlin Fiberglass Top Mount Filter Product Manual APT 750/ APT 900



★ FUNCTION

The filter Uses special filter sand to remove dirt particles from pool water. The filter sand is loaded into the filter tank and functions as the permanent dirt removing media. When the control valve is in the FILTER position, the pool water which contains suspended dirt particles, is pumped through the piping system and is automatically directed by the patented filter control valve to the top of filter tank. As the pool water is pumped through the filter, dirt particles are trapped by the sand bed, and filtered out. The cleaned Pool water is returned from the bottom of the filter tank, through the control valve and back to the pool through the piping system. This entire sequence is continuous and automatic and provides for total re-circulation of pool water through your filter and piping system.

After a period of time the accumulated dirt in the filter causes a resistance to flow, and the flow diminishes. This means it is time to clean your filter. With the control valve in the BACKWASH position, the water flow is automatically reversed through the filter so that it is directed to the bottom of the tank, up through the sand, flushing the previously trapped dirt and debris out the waste line. Once the filter is back-washed of dirt, set control valve to RINSE position and run pump for about 1/2 to 1 minute, and then to filter, to resume normal filtering.

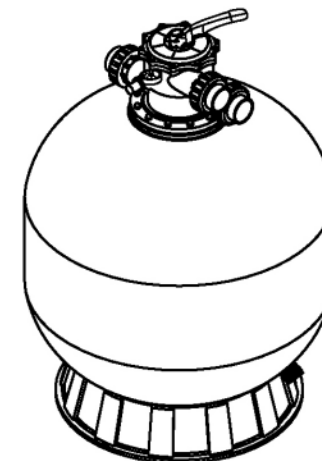

NOTE: Turn pump off before changing valve position.

★ INSTALLATION

Only simple tools (screwdriver and wrenches), plus pipe sealant for plastic adapters are required to install and service the filter.

- The filter should be placed on a level concrete slab, very firm ground, or equivalent position the filter so that the piping connections, control valve are convenient and accessible for operation and service.
- Loading the sand media. Filter sand media is loaded through the top opening of the filter.
 - Remove the screws, nuts and filter control valves (if previously installed).
 - Cap internal pipe with plastic cap to prevent sand from entering it.
 - We recommend filling tank approximately 1/2 way with water to provide a cushion effect when the filter sand is poured in. This helps to protect the under-drain laterals from excessive shock.
 - Carefully pour in correct amount and grade of filter sand. (Be sure center pipe remains centered in opening.) Sand surface should be leveled and should come to about the middle of the filter tank, Remove plastic cap from internal Pipe.
- Assemble filter control valve to filter tank.
 - Insert filter control valve (with O-ring in place) into the tank neck, ensuring the twelve bolts which are pre-embedded in the tank neck through the twelve holes round the valve, taking care that the center pipe slips into the hole in the bottom of the valve.
 - Put the twelve nuts and washers onto each of the twelve bolts, then screw all the nuts on with wrench, ensuring that all nuts are tight.
 - Carefully screw pressure gauge (with O-ring in place) into tapped hole in valve body. Do not over-tighten.
 - Connect pump to control valve opening marked PUMP. After connections are made, tighten valve flange clamps with screwdriver, tapping around clamp with screwdriver handle to help seat valve flange clamp.

4. Make return to pool pipe connection to control valve opening marked RETURN and complete other necessary plumbing connections, suction lines to pump, waste, etc.
5. Make electrical connections to pump per pump instructions.
6. To prevent water leakage, be sure all pipe connections are tight

★ MAIN DIMENSION

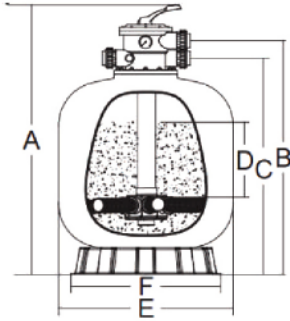

Model	Dimension(mm)					
	A	B	C	F	E	F
APT750	1150	980	900	390	750	710
APT900	1310	1160	1080	480	900	710

★ INSTALL/START-UP OF FILTER

1. Ensure the correct amount of filter media sand is located in the tank and all connections have been connected and secured.
2. Depress the control valve handle and rotate it to the BACKWASH position. (To prevent damage to the control valve seal, always depress the handle before turning.)
3. Prime and start the pump according to the pump instructions (make sure all suction and return lines are open), allowing the filter tank to fill with water. Once water is flowing out of the waste line, run the pump for 1 minute or more. The initial backwashing of the filter is recommended to remove any impurities or fine sand particles in the sand media.
4. Turn the pump off and set the valve to the RINSE position. Start the pump and operate it until the water in the sight glass is clear, for 1/2 to 1 minute. Turn the pump off and set the valve to the FILTER position, then restart the pump. The filter is now operating in the normal filter mode, filtering dirt particles from the pool water.
5. Adjust the pool suction and return valves to achieve the desired flow. Check the system and filter for water leaks and tighten connections, bolts, nuts, as required.
6. Note the initial pressure gauge reading when the filter is filtering. (It will vary from pool to pool depending upon the pump and general piping system.) As the filter removes dirt and impurities from the pool water, the accumulation in the filter will cause the pressure to rise and flow to diminish. When the pressure gauge reading is 1.5 bar higher than the initial "filter" pressure you noted, it is time to backwash the filter (see BACKWASH under filter and control valve functions).

NOTE: During the initial clean-up of the pool water, it may be necessary to backwash frequently due to the unusually heavy initial dirt load in the water.

★ INSTALSTART-UP OF FILTER

⚠ THIS FILTER OPERATES UNDER HIGH PRESSURE. WHEN ANY PART OF THE CIRCULATING SYSTEM (E.C., CLAMP, PUMP, FILTER, VALVES, ETC.) IS SERVICED, AIR CAN ENTER THE SYSTEM AND BECOME PRESSURIZED. PRESSURIZED AIR CAN CAUSE THE LID VALVE TO BE BLOWN OFFWHICH CAN RESULT IN SEVERE INJURY, DEATH, OR PROPERTY DAMAGE.

⚠ TURN THE PUMP OFF BEFORE CHANGING VALVE POSITION.

⚠ TO PREVENT DAMAGE TO THE PUMP AND FOR PROPER OPERATION OF THE SYSTEM, CLEAN THE PUMP STRAINER AND SKIMMER BASKETS REGULARLY.

⚠ DO NOT UNSCREW SCREWS OF VALVE WHILE THE PUMP IS RUNNING.

★ REPLACEMENT PARTS OF FILTER

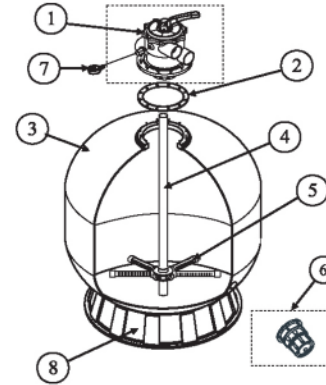

FILTER PARTS TABLE

ITEM	PART NO.	DESCRIPTION
1	1000-31	VALVE
2	1000-32	GASKET OF FLANGE
3	1000-33	FILTER TANK
4	1000-34	LATERALASSEMBLY WITH CENTER PIPE
5	1000-35	LATERAL
6	1000-36	UNDER DRAIN (for both sand and water)
7	1000-37	NUT HEX
8	1000-38	FILTER SUPPORT STAND

★ PLACEMENT PARTS OF MULTIPORT VALVE

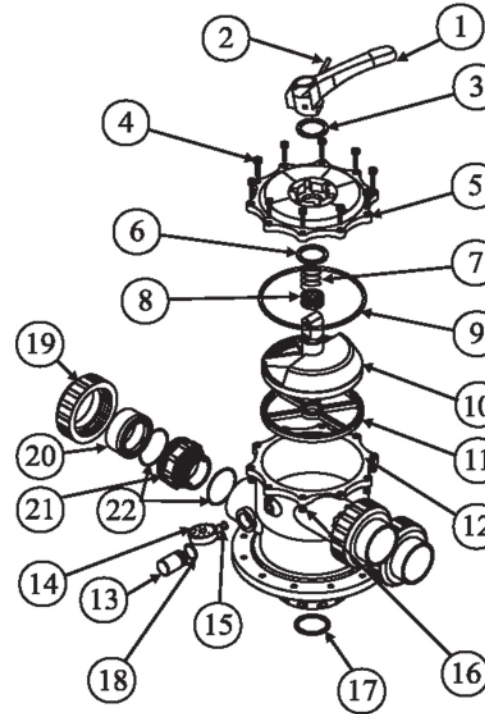

VALVE PARTS TABLE

ITEM	PART NO.	DESCRIPTION
1	WV31	HANDLE
2	WV32	LOCK PIN
3	WV33	WASHER
4	WV34	SCREW
5	WV35	COVER
6	WV36	SPRING
7	WV37	O'RING
8	WV38	O'RING OF COVER
9	WV39	DIVERTOR HEAD
10	WV40	DIVERTOR HEAD
11	WV41	GASKET
12	WV42	BODY
13	WV43	SIGHT GLASS
14	WV44	PRESSURE GAUGE
15	WV45	GASKET OF PRESSURE GAUGE
16	WV46	NUT HEX
17	WV47	O'RING
18	WV48	O'RING FOR SIGHT GLASS
19	WV49	UNION NUT
20	WV50	UNION HEAD
21	WV51	THREADED TAIL PIECE
22	WV52	O'RING