

PARIS PUMP

PROVEN LONG-TERM DURABILITY



PRODUCT FEATURES

Product Features:

- 2 inch suction and discharge ports
- Ring-lock lid eliminates leaks and maximizes suction efficiency
- Asynchronous, two-pole motor
- Class insulation: 130(B)
- IPX5 Waterproof standard
- Built-in thermal protection
- Overload protection
- Available in 50Hz or 60Hz for 220V/380V
- Specially designed unions compatible for both Imperial and Metric standards
- Testing Pressure (50PSI / 3.5Bar)
- 316 stainless steel shaft
- 316 stainless steel mechanical seal

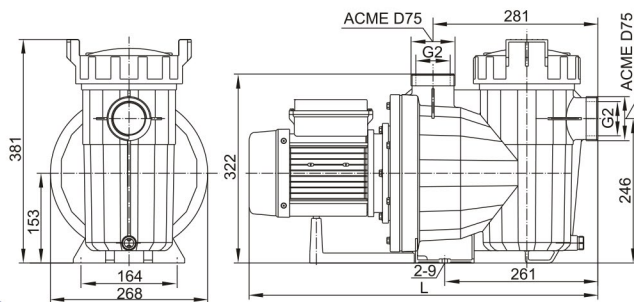

Aqua Pool Goup

Self priming pump for above or inground swimming pools. Reinforced fiberglass body for maximum durability. Equipped with an advanced hydraulic design that enables high performance and reduces the noise to the minimum. Powerful motor with inbuilt thermal protector. Double protection to isolate water from electricity

Aqua Pool Group Paris Series pump delivers high flow and energy efficiency ultra performance. 2inch suction and discharge port with a transparent lid. Ring lock seal design to eliminate suction leaks and to maximize suction efficiency.

Model	Qmax (l/min)	Hmax (m)	Power(P ₁)		L Single-phase
			KW	HP	
PA - 075	280	12	0.55	0.75	576
PA - 100	310	15.5	0.75	1.0	576
PA - 150	400	18	1.1	1.5	576
PA - 200	470	19	1.5	2.0	595
PA - 250	520	19.5	1.85	2.5	595
PA - 300	550	22	2.2	3.0	595
PA - 400	600	24	3.0	4.0	636